

S08-037
2008年5月吉日

パンドウイトコーポレーション日本支社
ビジネスディベロップメント事業部 ネットワークグループ

カテゴリ6&5E モジュラープラグ圧着工具の製品型番変更に関するご案内

拝啓、

新緑の候、貴社ますますご盛栄のこととお喜び申し上げます。
平素は格別のご高配を賜り、厚くお礼申し上げます。
長年に渡りご愛顧いただいております「カテゴリ6&5E モジュラープラグ圧着工具」の製品型番変更について、下記の通りご案内申し上げます。
今後とも相変わりなく当社商品をご用命いただけますようお願い申し上げます。

敬具

記

1. 対象製品

項	製品名	現行型番	新型番
1	カテゴリ6&5E モジュラープラグ圧着工具	MPT5-8	MPT5-8A

- *1. 新型番は、末尾に“A”が追加されます。
- *2. 一部デザイン変更がありますが、施工手順・取扱いは従来通り変更ありません。



前面



背面



梱包状態

2. 移行方法・時期

現行型番製品在庫が無くなり次第、新型番製品に順次移行します（ランニングチェンジ）。
なお、移行状況につきましては、担当営業までご確認願います。

—以上—

現行型番

THIS COPY IS PROVIDED ON A RESTRICTED BASIS AND IS NOT TO BE USED IN ANY WAY DETRIMENTAL TO THE INTERESTS OF PANDUIT CORP.

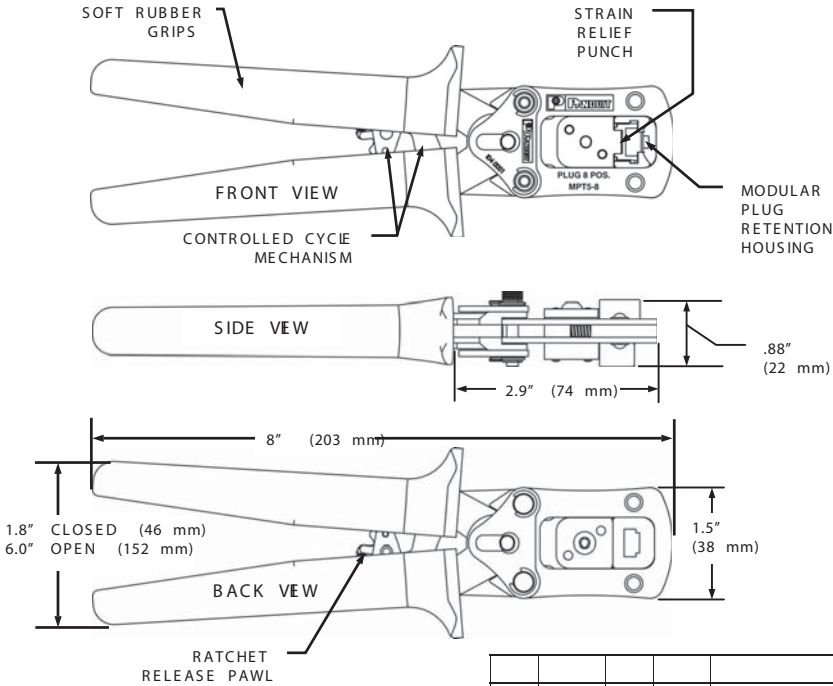

PANDUIT PART NO. _____ WEIGHT:
MPT5-8 Tool .67 lbs./each (300)
g./each

NOTES:

REQUIRED FOR PAN-PLUG™ AND TX6™ MODULAR PLUG TERMINATION.
CONTROLLED CYCLE TOOL TO INSURE PROPER PLUG TERMINATION.
REFERENCE OPERATION INSTRUCTIONS FOR PROPER USE OF TOOL.

ALL DIMENSIONS ARE FOR REFERENCE ONLY.

F:\workgrp\rvusers\ENGRDOCS-NEW\CUST DWG\CG24520B01_01 MPT5-8 CD.doc

							PANDUIT CORP. TINEY PARK, ILLINOIS		
							MPT5-8 CUSTOMER DRAWING		
							UNLESS OTHERWISE SPECIFIED, DIMENSIONAL TOLERANCES ARE:	UNLESS OTHERWISE SPECIFIED, ALL DIMENSIONS ARE GIVEN IN INCHES, THIRD ANGLE PROJECTION.	
							(x) ± ----	(xxx) ± ----	
							(xx) ± ----	ANGLES ± ----	
01	6-01-06R	MBR	UPDATE NOTES, LINE ART; REMOVE MPT5-8	4206	---	LAH	DRAWN BY BLR	MATL: -----	SCALE NONE
00	2-27-02R	MSH	RELEASED	4002	---	LAH	DATE: 2-27-02		DRAWING NO. CG24520B01
REV	DATE	BY	CHK'D	DESCRIPTION	ECN	- R	CUST	SUP	DWG B SIZE

新型番

THIS COPY IS PROVIDED ON A RESTRICTED BASIS AND IS NOT TO BE USED IN ANY WAY DETRIMENTAL TO THE INTERESTS OF PANDUIT CORP.

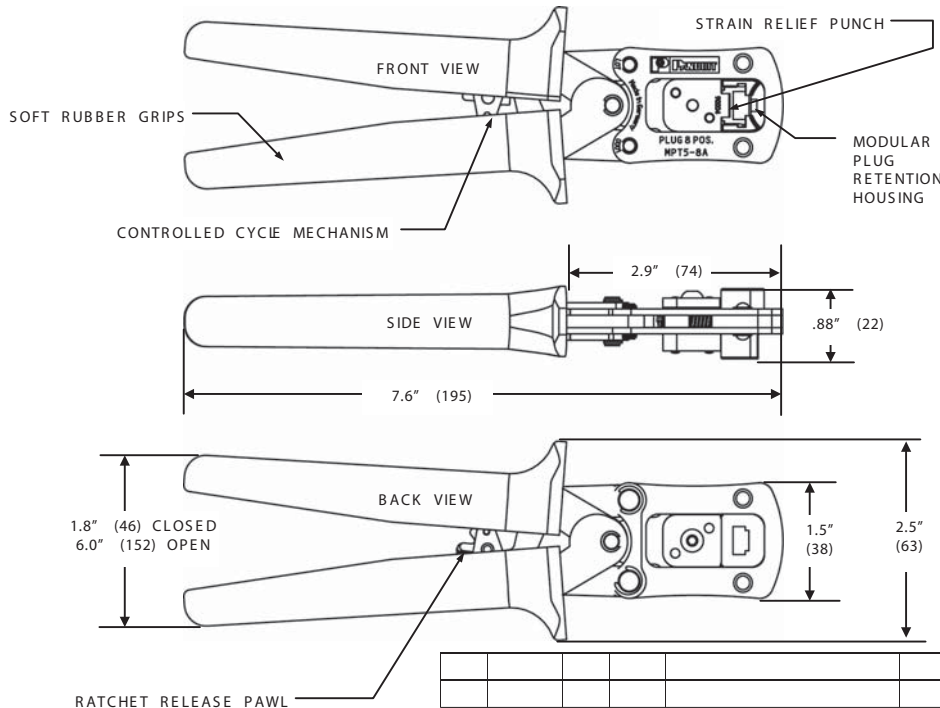

PANDUIT PART NO. MPT5-8A Tool
Weight: .62 lbs.(each) (approx. 280 g)
Length: 7.6" (approx. 195 mm)
Width: 2.5" (approx. 63 mm)

NOTES:

REQUIRED FOR PAN-PLUG™ AND TX6™ MODULAR PLUG TERMINATION.
CONTROLLED CYCLE TOOL TO INSURE PROPER PLUG TERMINATION.
REFERENCE OPERATION INSTRUCTIONS FOR PROPER USE OF TOOL.

ALL DIMENSIONS IN PARENTHESES ARE MILLIMETERS.

ALL DIMENSIONS ARE FOR REFERENCE ONLY.

F:\workgrp\rvusers\ENGRDOCS-NEW\CUST DWG\CG25626B01_01 MPT5-8A CD.doc

							PANDUIT CORP. TINEY PARK, ILLINOIS			
							MPT5-8A CUSTOMER DRAWING			
							UNLESS OTHERWISE SPECIFIED, DIMENSIONAL TOLERANCES ARE:	UNLESS OTHERWISE SPECIFIED, ALL DIMENSIONS ARE GIVEN IN INCHES, THIRD ANGLE PROJECTION.		
							(x) ± ----	(xxx) ± ----		
							(xx) ± ----	ANGLES ± ----		
01	5-29-08	BLR	MSH	CORR. BACK VIEW	4274A	---	ABJ	DRAWN BY BLR	MATL: -----	SCALE NONE
00	01-03-08	BLR	MSH	RELEASED	4274	---	JRWA	DATE: 01-03-08		DRAWING NO. CG25626B01
REV	DATE	BY	CHK'D	DESCRIPTION	ECN	- R	CUST	SUP	DWG B SIZE	