

カテゴリ6 & 5E共用 モジュラープラグ圧着工具
Part Numbers: MPT5-8A

©Panduit Corporation Japan Branch

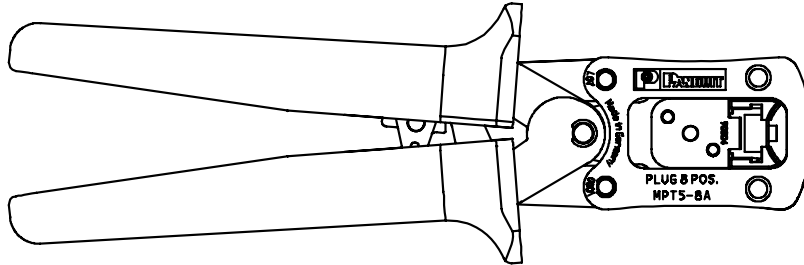

製品仕様

材質	本体	鉄
	ハンドルカバー	ポリウレタンゴム

寸法 詳細は別紙寸法図を参照(寸法はインチとなり、[]内はメートル表示です)

公称寸法	W 63.0 × L 195.0 × D 22.0 [mm]
------	--------------------------------

質量

公称重量	280.0 [g]
------	-----------

カラー

カラー	本体	BL (ブラック)
	ハンドルカバー	グリーン

改版履歴

版数	改版日	変更内容	担当
01	2008.05.02	初版制定	山之内

版	制定	作成	承認
01	2008年5月2日	山之内	新田

THIS COPY IS PROVIDED ON A RESTRICTED BASIS AND IS NOT TO BE USED IN ANY WAY DETRIMENTAL TO THE INTERESTS OF PANDUIT CORP.

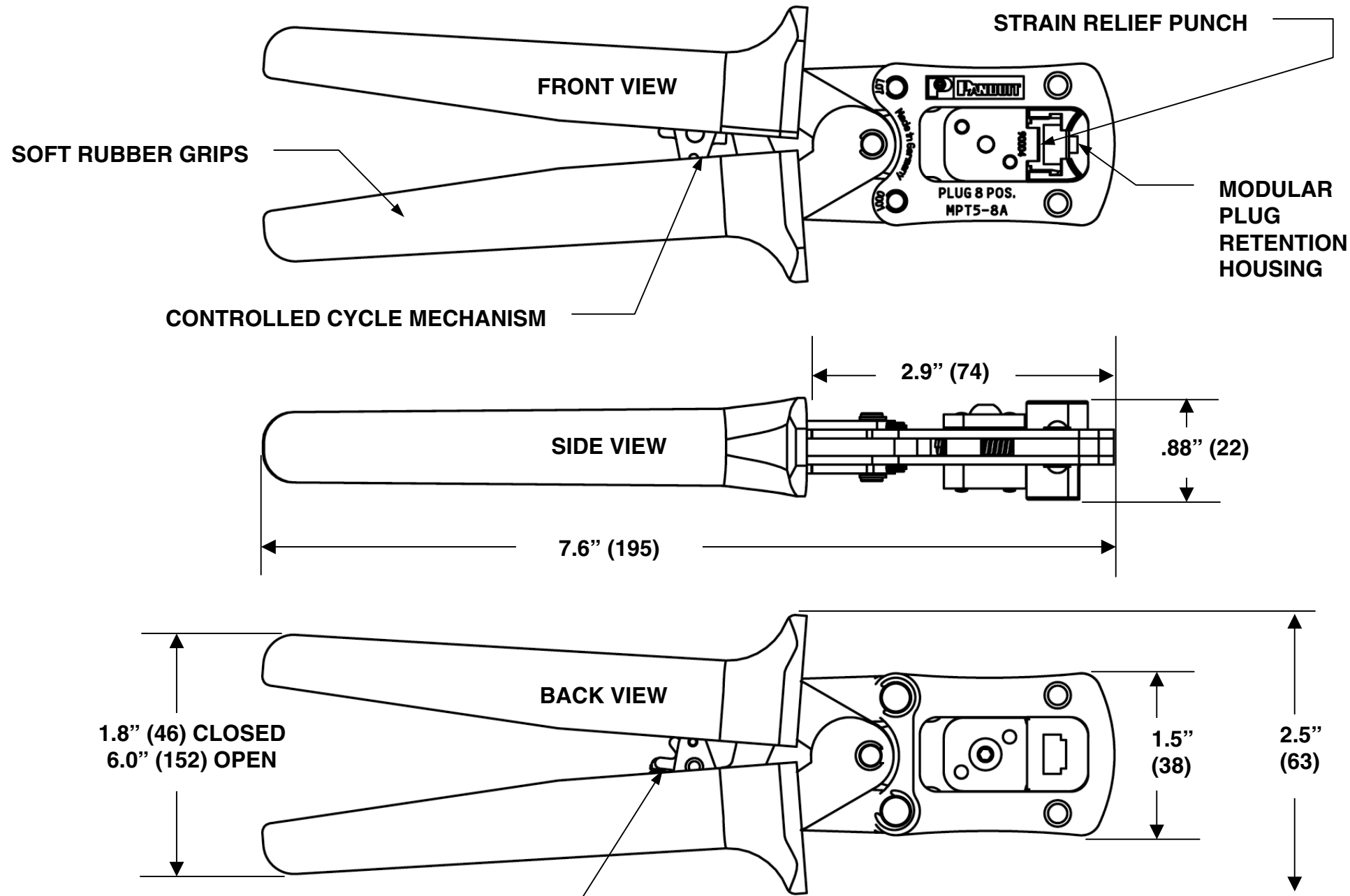

PANDUIT PART NO. MPT5-8A Tool
Weight: .62 lbs.(each) (approx. 280 g)
Length: 7.6" (approx. 195 mm)
Width: 2.5" (approx. 63 mm)

NOTES:

- REQUIRED FOR *PAN-PLUG™* AND *TX6™* MODULAR PLUG TERMINATION.
- CONTROLLED CYCLE TOOL TO INSURE PROPER PLUG TERMINATION.
- REFERENCE OPERATION INSTRUCTIONS FOR PROPER USE OF TOOL.

ALL DIMENSIONS IN PARENTHESES ARE MILLIMETERS.

ALL DIMENSIONS ARE FOR REFERENCE ONLY.

F:\wrkgrp\rvusers\ENGRDOCS-NEW\CUST DWG\CG25626B01_01 MPT5-8A CD.doc

PANDUIT CORP. TINLEY PARK, ILLINOIS

**MPT5-8A
 CUSTOMER DRAWING**

UNLESS OTHERWISE SPECIFIED, DIMENSIONAL TOLERANCES ARE:
 (.x) ± ---- (.xxx) ± ----
 (.xx) ± ---- ANGLES ± ----

UNLESS OTHERWISE SPECIFIED, ALL DIMENSIONS ARE GIVEN IN INCHES, THIRD ANGLE PROJECTION.

DRAWN BY:
BLR
 DATE:
01-03-08
 CHK'D:
MSH

MATL:

SCALE
NONE
 DRAWING NO.
CG25626B01
 DWG SIZE
B

REV	DATE	BY	CHK'D	DESCRIPTION	ECN	- R	CUST	SUP
01	5-29-08	BLR	MSH	CORR. BACK VIEW	4274A	---	ABJ	
00	01-03-08	BLR	MSH	RELEASED	4274	---	JRWA	